

Programmed with Eaton Pro-FX® control software

32-bit processor, 20 I/O (10 inputs & 10 outputs), 3 CAN interfaces
supply voltage 6-32 VDC

The high-performance HFX20m control unit is designed for electronic control of all system functions on and off-highway mobile equipment. This control unit features a powerful processor, configurable CAN channels and a flexible I/O system to meet the needs of a variety of demanding applications.

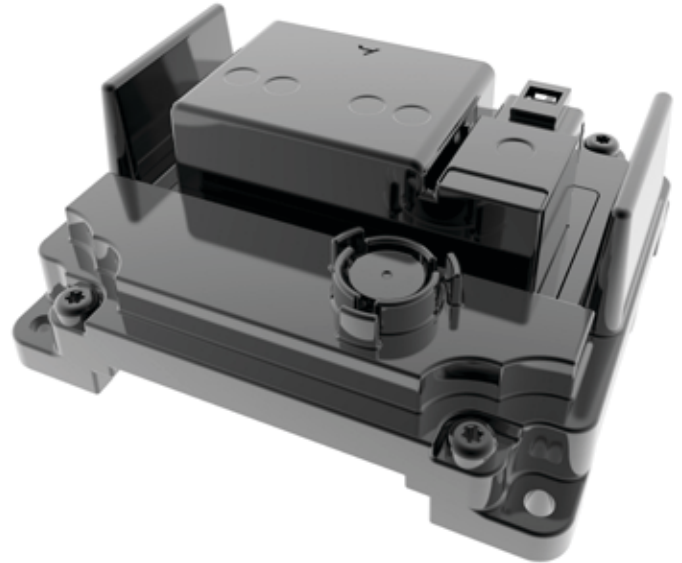

Technical data

Dimensions	L: 5.3 in (134.2 mm) x W: 5.8 in (146.2 mm) x H: 2.3 in (58.6 mm)
Weight	1.85 lbs (0.84 kg)
Storage temperature range	-40 - +125 °C
Operating temperature range	-40 - +105 °C (USB use is limited to 85°C)
IP rating	IP67, IP69k
Operating altitude	0 - 4000 m
Supply voltage	6 - 32 VDC, nominal operation @ 12 /24 VDC
Peak supply voltage	36 VDC
Maximum load current	20A @ 105°C (24A @ 85°C)
Standby current 12/24 VDC	<3.5 mA@12 V, <2.5 mA@24 V
Processor	32 bit, 200 MHz, Renesas Super H 72546
Floating point units	Integrated on chip
MRAM (additional to CPU)	32 Kbyte approx. 1 trillion writes
Flash (ROM program & data combined)	3.75 Mbyte 1000 writes
SRAM	256 Kbyte
EEPROM	128 Kbyte (system use only)



Powering Business Worldwide

Technical data

Communications

CAN 1 interface	2.0A, 2.0B
Baud rates	125 kb/s, 250 kb/s, 500 kb/s, 1 Mb/s
Protocol	CANopen, J1939
Default node address	0
Default baud rate	250 kb/s
CAN 2 interface	2.0A, 2.0B
Baud rates	125 kb/s, 250 kb/s, 500 kb/s, 1 Mb/s
Protocol	CANopen, J1939
CAN 3 interface	2.0A, 2.0B
Baud rates	125 kb/s, 250 kb/s, 500 kb/s, 1 Mb/s
Protocol	CANopen, J1939
USB interface	USB 2.0 (Note: 3.0 devices are compatible), used for programming
Baud rates	1.5 Mb/s

Sensor supply

Number of sensor supplies	1
Sensor supply output voltage	5/10 VDC (software configurable)
Sensor supply maximum current	200 mA @ 5 VDC, 100 mA @ 10 VDC per supply (Note: sensor supply is de-rated to 50 mA @ 10 VDC on 24 VDC systems with ambient temperatures at or above 85°C)

Technical data

Inputs

Digital input	Digital low/high side (software configurable)
Input frequency	200 Hz
Switch-on level	Software configurable
Switch-off level	Software configurable

Frequency input	Digital Low/high side (software configurable)
Input frequency	0 Hz - 50 kHz Note: maximum aggregate is 200 kHz, minimum detectable pulse duration is 20 μ sec

Frequency input	Variable reluctance (software configurable)
Input frequency	0 Hz - 25 kHz Note: maximum aggregate is 200 kHz, minimum detectable pulse duration is 20 μ sec
Switch-on level	Selectable as 2.2 V or adaptive
Switch-off level	Selectable as 0.0 V or 1.0 V

Analog input	0 - 5 V (absolute & ratiometric), 0 - 10 V, 0 - 32 V , 0 - 20 mA, thermistor (software configurable)
Resolution	12 bits
Accuracy	+/- 0.2 % FS (0-5 VDC mode), +/- 1 % FS (all other modes)
Short circuit protection	Integrated

Voltage input	0 - 5 V
Input frequency	1 kHz

Voltage input	0 - 10 V
Input frequency	1 kHz

Voltage input	0 - 32 V
Input frequency	1 kHz

Thermistor input

Input resistance	22 kOhm pull-up
Sample frequency	1 kHz
Accuracy	+/-1%
Current input	0 - 20 mA
Input frequency	1 kHz

Technical data

Outputs	
Digital output – 2A	High side
Max amperage	2A
Diagnostics	Open/short circuit protection
PWM output current feedback – 2A	High side (software configurable)
Max amperage	2A
Diagnostics	Open/short circuit protection
PWM frequency	.05 Hz – 2 kHz or 50 Hz – 2 kHz
Dither frequency	Configurable
Dither amplitude	Configurable
Control range	0.05 - 2A
Control resolution	1 mA
Fly back protection	Integrated
Duty cycle resolution	.01% @ 250 Hz
Digital output – 4A	Low/high side, H-bridge (software configurable)
Max amperage	4A
Diagnostics	Open/short circuit protection
PWM output current feedback – 4A	Low/high side, H-bridge (software configurable) in PWM mode, high side (software configurable) in current control mode
Max amperage	4A
Diagnostics	Open/short circuit protection
PWM frequency	50 - 500 Hz
Dither frequency	Configurable
Dither amplitude	Configurable
Control range	0.05 - 4A
Control resolution	1.5 mA
Fly back protection	Integrated
Duty cycle resolution	.01% @ 250 Hz
Connections	
Connector – 6 Pin	Deutsch Inc.
Model	DT04-6P
Contact surface	Nickel plated
Connector – 40 Pin	Deutsch Inc.
Model	DRC23-40PA
Contact surface	Nickel plated
Torque specification	25-28 in-lbs (2.82 - 3.16 N-m)

Technical data

Standards

Temperature environment	SAE J1455
Environmental	SAE J1455
Salt spray	J1455 Section 4.3.3
Vibration	J1455 Section 4.10.4.1
Drop	J1455 Section 4.11.3.1
Shock	J1455 Section 4.10.4
Conducted immunity	SAE J1113, EN 61326-1, 2004/108/EC
Radiated immunity	SAE J1113, EN 61326-1, 2004/108/EC
Conducted emissions	CISPR 25, EN 60945, 2004/108/EC
Radiated emission	CISPR 25, CISPR 11, EN60945

Certifications

CE Mark

e-Mark

Block diagram

HFX20m

6A	VBATT+
26A	Sleep
16A	IGN

Controller power

VBATT-	7A
--------	----

9A	Load_PWR+
10A	Load_PWR+
19A	Load_PWR+

Output power

Load_PWR-	18A
Load_PWR-	28A
Load_PWR-	29A

1P	USB_GND
2P	USB_D-
3P	USB_D+
6P	USB_+5V

Programming interface

4P	CAN1_H
5P	CAN1_L

Sensor power supply 1

SENS_PWR+	30A
SENS_PWR-	20A

22A	CAN1_H
12A	CAN1_L

CAN Bus
(J1939/CANopen)

13A	CAN2_H
23A	CAN2_L

14A	CAN3_H
24A	CAN3_L

21A	INPUT_1
11A	INPUT_2
33A	INPUT_3
34A	INPUT_4
25A	INPUT_5
15A	INPUT_6

Analog/Digital inputs (0..5V, 0..10V, 0..34V, 0..22mA, thermistor, digital high/low side, variable reluctance*)

I/O System (10 inputs/
10 outputs)

PWM/Digital outputs - 2A (current feedback, digital high side)

PWM1_2A	2A
PWM2_2A	3A
PWM3_2A	4A
PWM4_2A	5A
PWM5_2A	40A
PWM6_2A	32A

36A	FREQ1_POS
37A	FREQ1_NEG
38A	FREQ2_POS
39A	FREQ2_NEG
17A	FREQ3
27A	FREQ4

Frequency/Digital inputs (digital high/low side, variable reluctance*)

PWM/Digital outputs - 4A (current feedback, digital high/low side)

PWM1_4A	1A
PWM2_4A	35A
PWM3_4A	31A
PWM4_4A	8A

*Note: Only FREQ1 & FREQ2 support variable reluctance type sensors inputs

Pin list

Communications connector

Type	Deutsch	DT04-6P
Pin	Function	
1	Ground	
2	USB data low	
3	USB data high	
4	CAN 1 high	
5	CAN 1 low	
6	USB power 5V	

Connector A

Type	Deutsch	DRC23-40PA
Pin	Function	
1	Output PWM1 4A	
2	Output PWM1 2A	
3	Output PWM2 2A	
4	Output PWM3 2A	
5	Output PWM4 2A	
6	System power positive	
7	System power negative	
8	Output PWM4 4A	
9	Load power positive	
10	Load power positive	
11	Input 2	
12	CAN 1 low	
13	CAN 2 high	
14	CAN 3 high	
15	Input 6	
16	Ignition	
17	Frequency 3	
18	Load power negative	
19	Load power positive	
20	Sensor power 1 negative	
21	Input 1	
22	CAN 1 high	
23	CAN 2 low	
24	CAN 3 low	
25	Input 5	
26	Sleep	
27	Frequency 4	
28	Load power negative	
29	Load power negative	
30	Sensor power 1 positive	
31	Output PWM3 4A	
32	Output PWM6 2A	
33	Input 3	
34	Input 4	
35	Output PWM2 4A	
36	Input frequency 1 positive	
37	Input frequency 1 negative	
38	Input frequency 2 positive	
39	Input frequency 2 negative	
40	Output PWM5 2A	

Mounting diagram

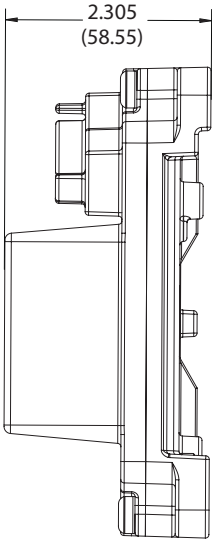
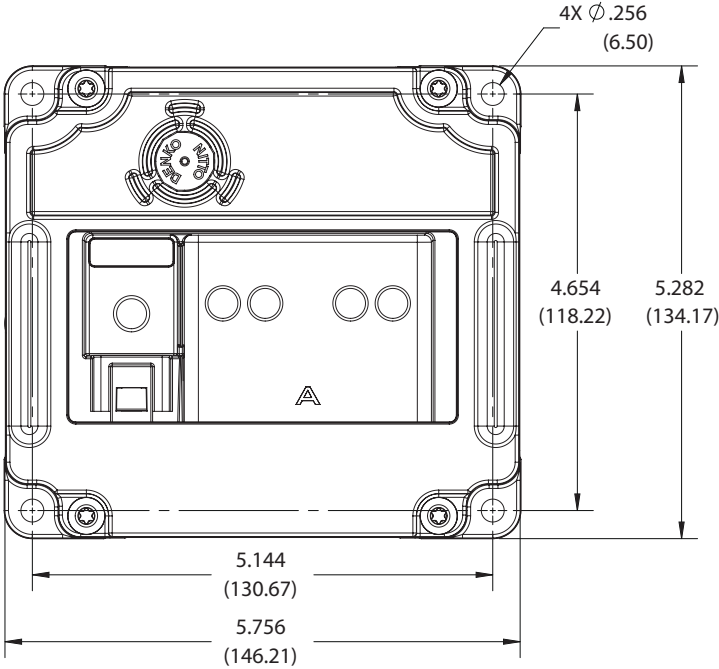

Deutsch Industrial,
Connector Plug-DT04-6P
Connector Plug-DRC23-40PA

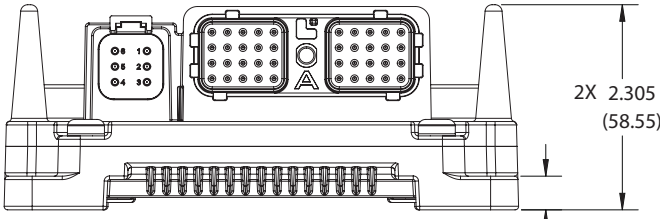

Eaton
Hydraulics Group USA
14615 Lone Oak Road
Eden Prairie, MN 55344
USA
Tel: 952-937-9800
Fax: 952-294-7722
www.eaton.com/hydraulics

Eaton
Hydraulics Group Europe
Route de la Longeraie 7
1110 Morges
Switzerland
Tel: +41 (0) 21 811 4600
Fax: +41 (0) 21 811 4601

Eaton
Hydraulics Group Asia Pacific
Eaton Building
No.7 Lane 280 Linhong Road
Changning District,
Shanghai 200335
China
Tel: (+86 21) 5200 0099
Fax: (+86 21) 2230 7240